

Cirio Oval

Antoni Arola. 2010
Pendant lamps



Lampshades



Canopies



Combining straight sections and semi-circles, Cirio Oval creates oval-shaped compositions of varying dimensions. By connecting linear and curved structures, it allows for large-scale luminaires with a balanced, continuous geometry.

Since ancient times, mosques have used large chandeliers suspended in concentric rings as symbols of unity and transcendence. These floating structures create a sense of weightlessness and harmony within the space. With its enveloping and solemn effect, Cirio offers a reinterpretation of that tradition, aiming to elevate the spirit.

The Cirio family has four shade options. The handcrafted Sargadelos porcelain, whose translucence bathes the white shade in amber, provides a diffuse and very warm light. In its striped version, it also gains texture and three-dimensionality. For greater luminous efficiency, opal glass offers a more intense and economical alternative. Finally, the opacity of brass allows for focused, directional lighting.

General description:

Capsule with LED module, translucent white diffuser and heat sink with black matte finish.

4 lampshade options: white porcelain, white Pana porcelain, white opal glass and polished brass.

2 options of adjustable matte black metallic canopy with built-in equipment: circular (European version): regulation DALI / DSI / SWITCH DIM, or rectangular: regulation 1-10V / DALI.

Matte black aluminum structure.

Combination of the linear and circular M (ø 300 cm / 118.1") models.

Suitable for Junction Box (American version).

Electric cable length: 5 m / 196.9"

Approximate weight (unpacked):

46 kg / 101.5 lb*

Lampshades:

Porcelain: 0,5 kg / 1.1 lb

Pana porcelain: 0,4 kg / 0.8 lb

Glass: 0,6 kg / 1.3 lb

Brass: 0,3 kg / 0.7 lb

*Weight with porcelain lampshade

Cirio Oval

Antoni Arola. 2010
Pendant lamps

Technical information:

Dimmable light source included. LED module

Circular canopy (European version):

Rated input wattage (LED capsule): 5,5 W
Operating current: 350 mA
CCT: 2.700 K
CRI: 90
Lifetime: 40.000 h

28 + 5 + 5 light sources
Rated input wattage: 168 W
Luminous flux:
Porcelain 4.674 lm
Pana porcelain 6.650 lm
Glass 13.756 lm
Brass 4.978 lm

Built-in LED.

European version: regulation DALI / DSI / SWITCH DIM.
Suitable only for indoor use.

Input voltage: 120 ~ 277 Vac.
(50 Hz / 60 Hz). According to destination.

Rectangular canopy:

Rated input wattage (LED capsule): 11 W
Operating current: 700 mA
CCT: 2.700 K
CRI: 90
Lifetime: 40.000 h

28 + 5 + 5 light sources
Rated input wattage: 343,5 W
Luminous flux:
Porcelain 8.436 lm
Pana porcelain 11.666 lm
Glass 24.928 lm
Brass 9.006 lm

Built-in LED.

European version: suitable for dimming 1-10V / DALI.
Not included external dimmer switch 1-10V / DALI.
American version: suitable for dimming 1-10V.
Not included external dimmer switch 1-10V.
Suitable only for indoor use.

Input voltage: 120 ~ 277 Vac.
(50 Hz / 60 Hz). According to destination.

White porcelain lampshade

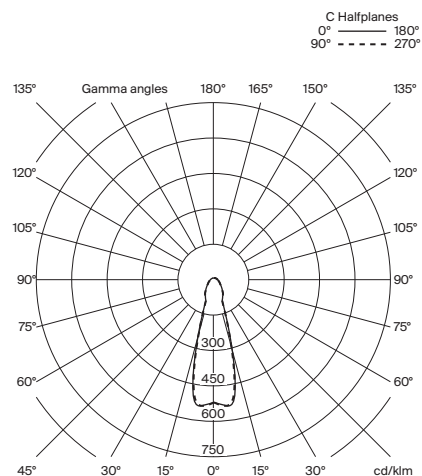

White Pana porcelain lampshade

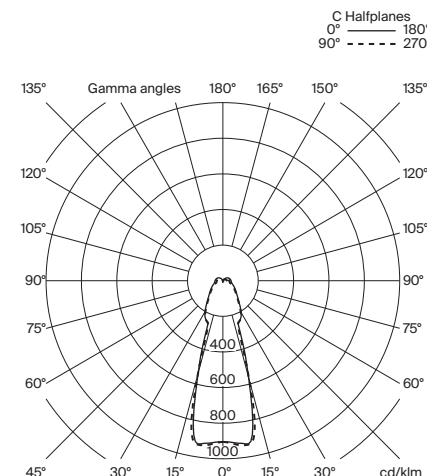

White opal glass lampshade

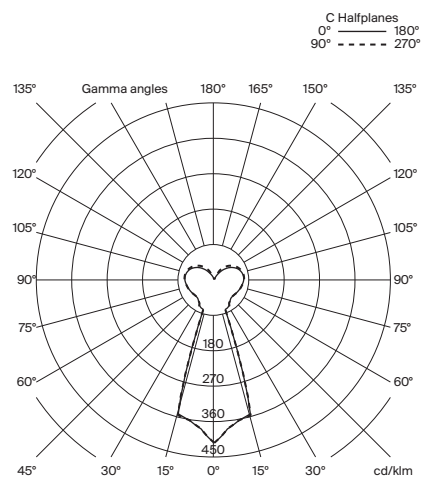

Brass lampshade

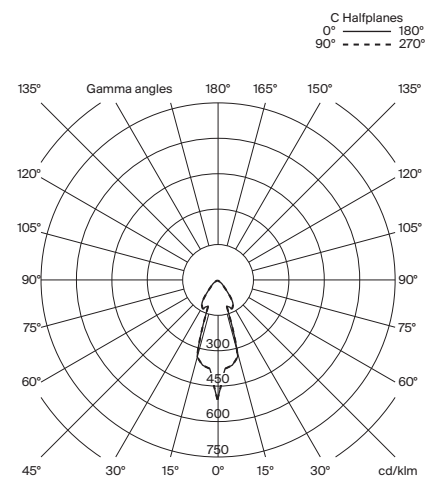

Cirio Oval

Antoni Arola. 2010
Pendant lamps

Regulations:

European version
UNE-EN 60598
UNE-EN 55015
UNE-EN 62031
UNE-EN 60529
UNE-EN 61000-3-2

American version
Dry and damp location
UL-1598
UL-8750
E-336377

Maintenance:

Clean with a smooth cloth. Do not use ammonia, solvents or abrasive cleaning products.

Others:

The lamp is delivered in different packages.
The assembly instructions are delivered with the product.

Model: Lampshades

White porcelain

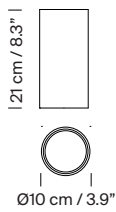

White Pana porcelain

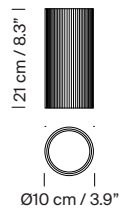

White opal glass

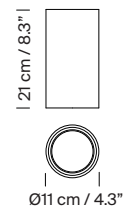

Brass

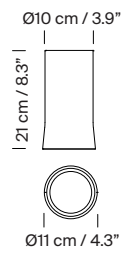

Models / Codes: European Version

Model (M+A+B): Cirio Oval

Circular Canopy

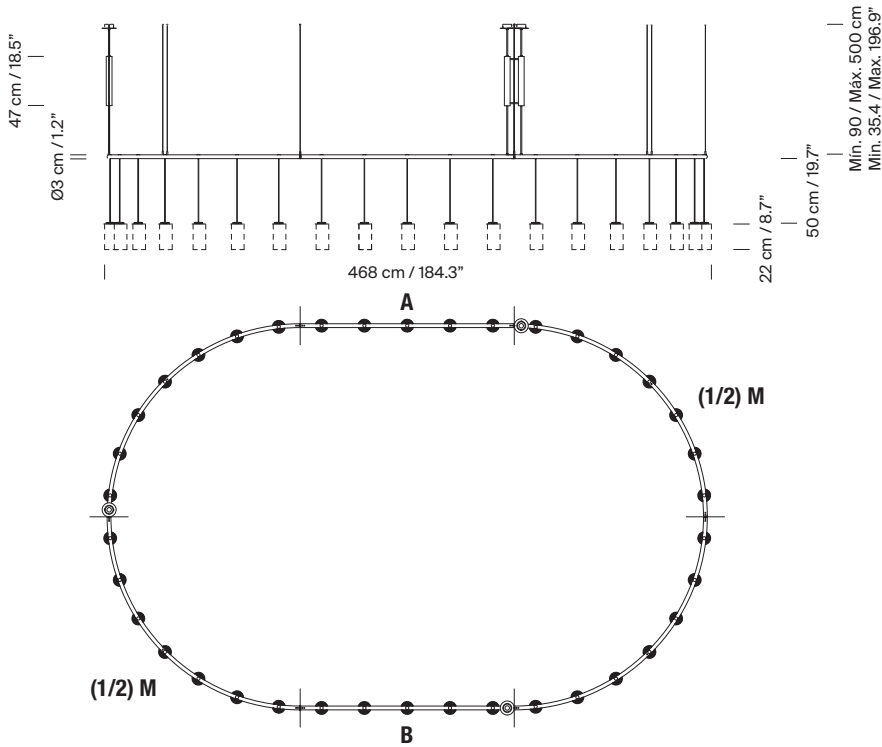

Lampshade	Canopy	Dimming	Code
White porcelain	Circular	DALI / DSI / SWITCH DIM	CIRPD01
White Pana porcelain	Circular	DALI / DSI / SWITCH DIM	CIRPD07
White opal glass	Circular	DALI / DSI / SWITCH DIM	CIRPD03
Brass	Circular	DALI / DSI / SWITCH DIM	CIRPD05

Models / Codes: European Version

Model (M+A+B): Cirio Oval

Rectangular canopy

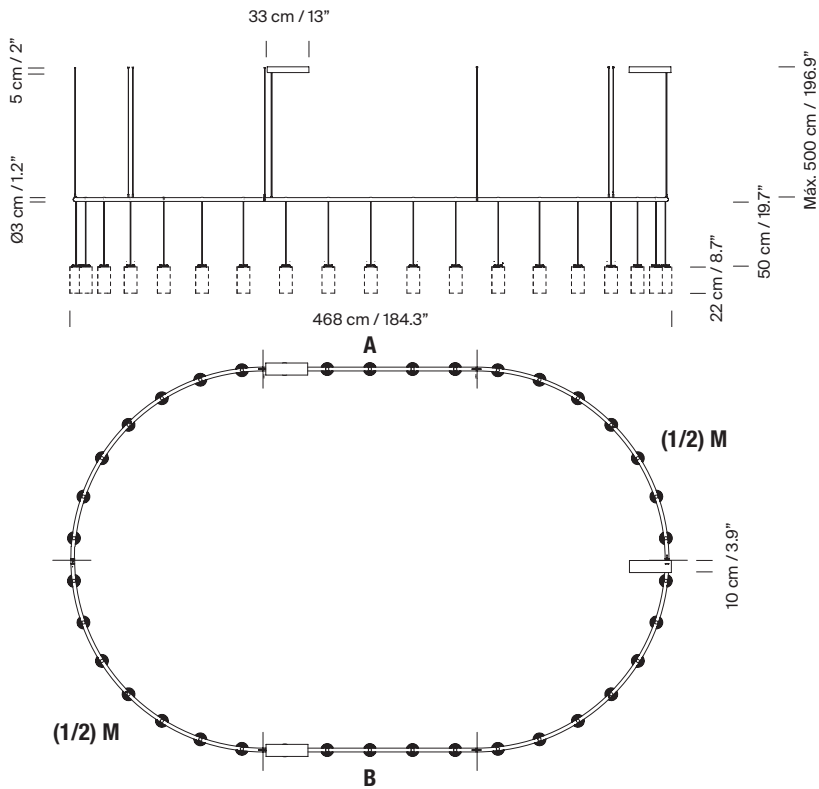

Lampshade	Canopy	Dimming	Code
White porcelain	Rectangular	1-10V	CIRPD02
	Rectangular	DALI	CIRPD02D
White Pana porcelain	Rectangular	1-10V	CIRPD08
	Rectangular	DALI	CIRPD08D
White opal glass	Rectangular	1-10V	CIRPD04
	Rectangular	DALI	CIRPD04D
Brass	Rectangular	1-10V	CIRPD06
	Rectangular	DALI	CIRPD06D



Models / Codes: American Version

Model (M+A+B): Cirio Oval

Rectangular canopy

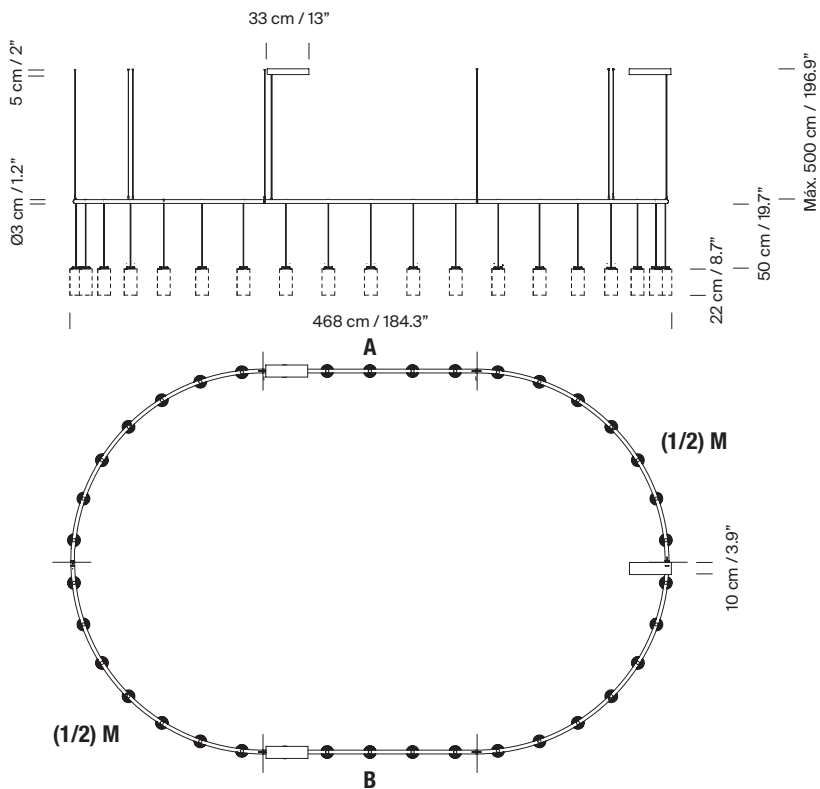

Lampshade	Rectangular canopy	Code
White porcelain	1-10V Dimming	CIRPD02UL
White Pana porcelain	1-10V Dimming	CIRPD08UL
White opal glass	1-10V Dimming	CIRPD04UL
Brass	1-10V Dimming	CIRPD06UL

Collection:
Pendant lamps



Cirio Simple



Cirio Múltiple



Cirio Cascada



Cirio Circular



Cirio Oval



Cirio Chandelier

Wall lamps

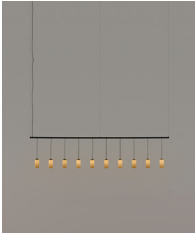

Cirio Lineal



Cirio Cuadrada



Cirio Pana



Cirio